

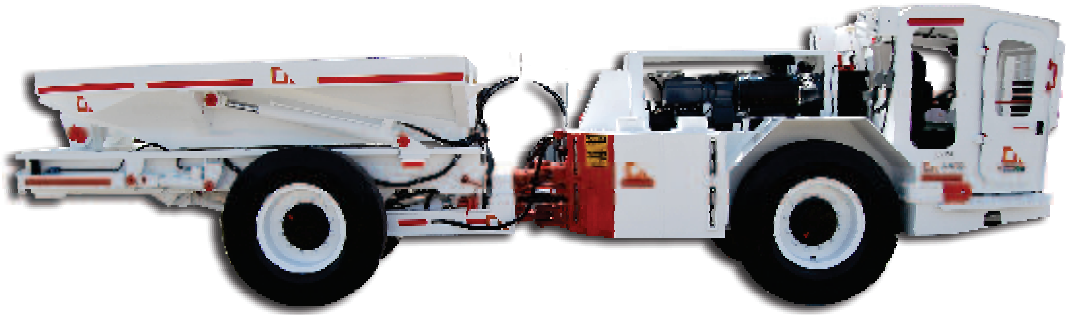

AARD UV100 ROLL ON ROLL OFF



FEATURES

SAFE WORKING ENVIRONMENT

- ISO ROPS/FOPS certified
- Spring applied, hydraulic release (SAHR) brakes
- Optional monitor (cameras) to increase operator's visibility during operation
- Door interlock

ENVIRONMENTAL

- Fuel efficient, clean burning Tier 2/Stage II engine
- Purifier with catalytic converter

SERVICEABILITY

- All daily check points easily reachable
- Quick and easy service to increase productivity

- Air, hydraulic and transmission filter change indicators
- Easy access to service points, filters and valve blocks

OPERATOR'S COMFORT

- Comfortable T-back seat with suspension
- Steering wheel ergonomically placed
- Single seat or dual seat compartment optional

RELIABILITY

- Proven powertrain Clark powershift transmission
- Electrical gear control in cab
- Machine status indication lights

SPECIFICATIONS

■ Vehicle height	2 252mm
■ Vehicle length	8 412mm
■ Vehicle width	2 080mm
■ Ground clearance	453mm
■ Inner turning radius	4 302mm
■ Outer turning radius	6 813mm
■ Gross vehicle weight no bin	11 700kg
with empty bin	14 500kg
■ Maximum carrying capacity	10 000kg

ENGINE

■ Type	BF6L914
■ Power rating	92kW at 2 300rpm
■ Torque	460Nm at 1 500rpm
■ Fuel consumption	220g/kWh
■ Engine protection	As per customer requirements
■ Air cleaner	Two stage
■ Catalytic converter	
■ Diluter	

TRANSMISSION/TORQUE CONVERTER

■ Three speed forward and reverse with integral converter	
■ Dana	T20 000 series

AXLES

■ Dana	113
--------	-----

BRAKES

■ Failsafe brake on all four wheels	
■ Type	SAHR

TYRES

■ Tyre size	1200-20/1200-24
■ Designed for underground mine services	
■ Pnuematic or foam-filled	

ELECTRICAL SYSTEM

■ 24V system	
■ Alternator	28V/55A
■ Isolation switch lockout	

HYDRAULIC SYSTEM

■ System pressure	17.5MPa
■ Pump type	Gear pump
■ Flow rate	2 x 36 litres/min at 2 300rpm
■ Hydraulic tank capacity	150 litres
■ Hydraulic level switch detection	

FUEL SYSTEM

■ Fuel tank capacity	85 litres
----------------------	-----------

SAFETY

- Fire extinguisher
- Reverse hooter
- Door interlock
- Marker lamps red/green
- Wheel stop blocks

OPTIONAL EQUIPMENT

- Manually/automatically actuated fire suppression engine shut down
- Central lubrication management system
- Automatic lubrication system
- Halogen, LED or sealed beam lights

DOCUMENTS

- Parts manual
- Technical manual
- Risk assessment



TOP VIEW

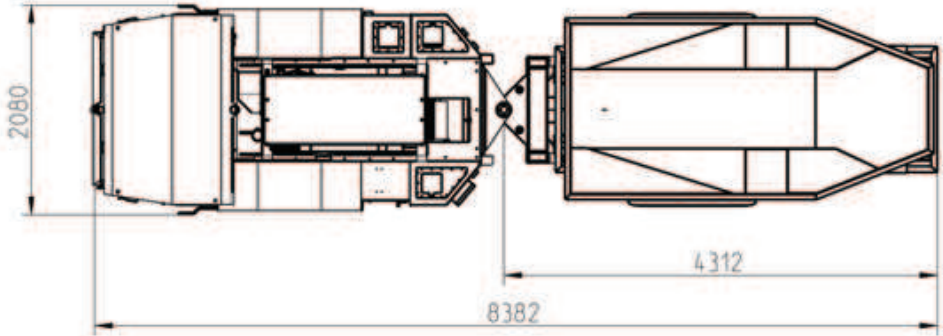

SIDE VIEW

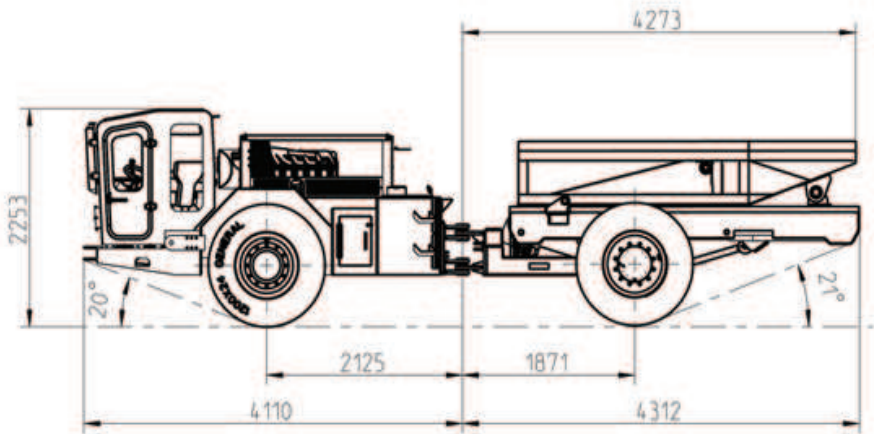

TRAMMING POSITION

AARD Mining Equipment is constantly striving to improve its products and therefore reserves the right to change the designs, materials, specifications and price without prior notice.

PRODUCTS & EQUIPMENT
44 Jacobs St., Chamdor, 1739
PO Box 3992, Witbeek 1729, South Africa
E-mail: info@aardme.co.za
Website: www.aardme.com

